

BSL Gas Technologies Limited

Mixing Knowledge and Resource Delivering Thought Provoking
Industrial Gas Solutions



BOC WEMBLEY

BOC Part No 19310911
BSL Stock Code BA406
BSL Drawing No 101047

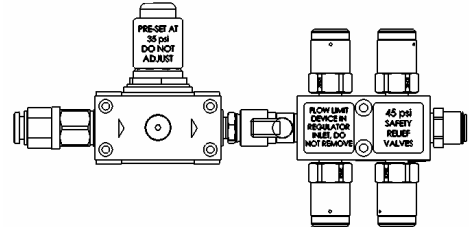

Item	Parts List - Details	BSL Code
1	Manifold Block	BM126
2	Pressure Relief Valve	BV086
3	Isolating Valve	BV055
4	Regulator Assembly	BA434

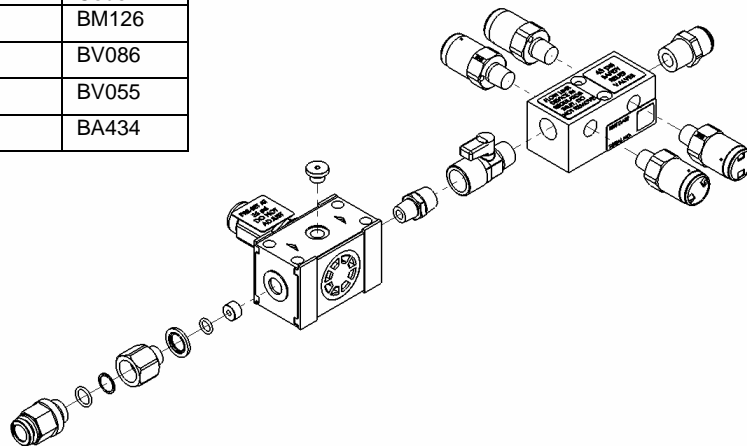

- In line CO₂ regulator assembly with pressure relief valves for beer dispense
- Design pressure 13 barg
- Drawing shows assembled and exploded views
- Footprint size – 275mm x 135mm
- Main block is aluminium anodised black
- Pressure relief valves are 45 psig – Brass construction.
- Sub assembly is wall mounted – Fixing holes in main block and regulator assembly
- The assembly is complete with a G3/8 isolating valve
- Assembly is identified by serial number for code of practice details and records
- Assembly includes in line regulator pre set at 35 psig
- Assembly includes 250 mesh in line filter
- Assembly includes orifice disc at inlet to regulator for pressure control
- Orifice disc must not be removed
- Outlet connection is ½” tube and is designed as a push in connection

BSL Gas Technologies Limited
No 101 Laker Road, Rochester Airport Industrial Estate
Rochester, Kent ME1 3QX



Tel ++ 44 1634 661100 Fax ++ 44 1634 671111
Email info@bslgastech.com www.bslgastech.com